



INSTALLATION INSTRUCTIONS FOR PART 99-7402

APPLICATIONS

Nissan 350Z 2003-2005

99-7402

KIT FEATURES

- DIN Radio Provision with pocket
- ISO Radio Provision with pocket
- Two stacked ISO units provision
- Double DIN radio provision



KIT COMPONENTS

A) Radio Housing with Pocket B) Double DIN Trim-plate C) ISO Spacer Brackets D) ISO Snap-in Brackets E) ISO Trim-plate

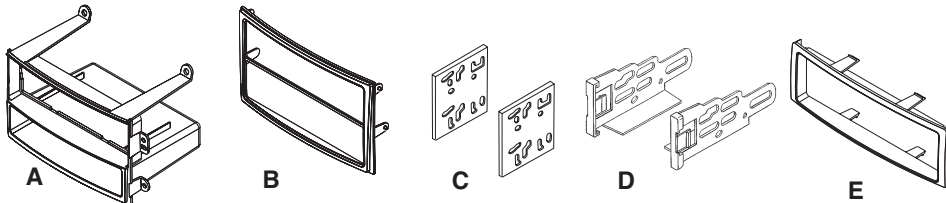

TOOLS REQUIRED:

Panel Removal Tool or
Small Flat Blade Screwdriver

Phillips Screwdriver

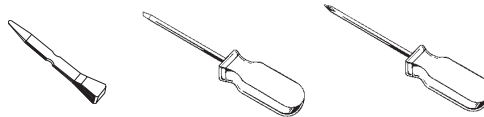

1-800-221-0932



www.metraonline.com

© COPYRIGHT 2004 METRA ELECTRONICS CORPORATION



TABLE OF CONTENTS

Dash Disassembly Nissan 350Z 2003-2005.....1, 2

Kit Assembly

Din Mount Radio Provision with pocket.....3

ISO Mount Radio Provision with pocket.....4

Double DIN Radio.....5

Two Stacked ISO mount units.....6

Final Assembly 7

NISSAN 350Z 2003-2005

- 1 Disconnect the negative battery terminal to prevent an accidental short circuit.
- 2 For vehicles with automatic transmission, Unsnap and remove smaller trim-ring from around shifter. (Figure A)

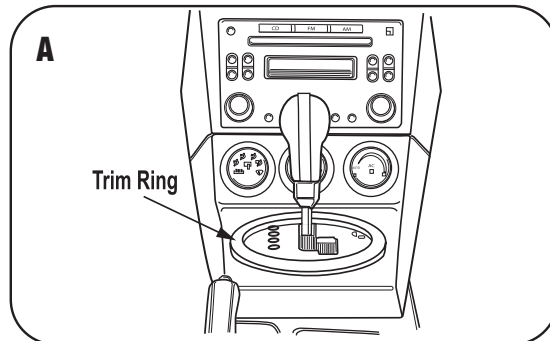

For vehicles with manual transmission, Unscrew and remove shifter knob. (Figure A)

- 3 Unsnap and remove center console trim panel including climate controls. (Figure B)



- 4 For vehicles with navigation, Unsnap and remove navigation switch panel. (Figure C)

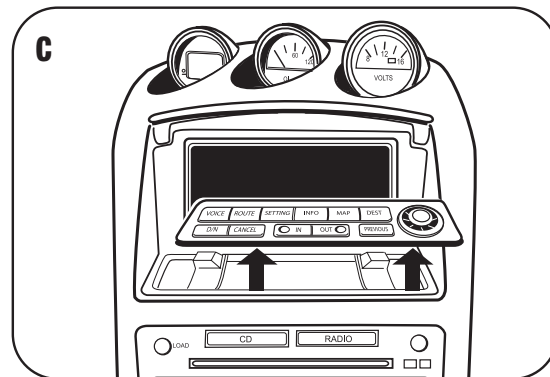

- 5 For vehicles without navigation, remove pocket mat, then remove two screws that secure switch mask. (Figure D)

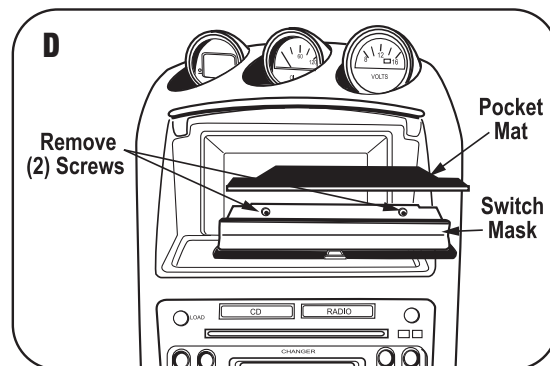



99-7402 DASH DISASSEMBLY

NISSAN 350Z 2003-2005

- 6** Remove (2) screws above the radio and (2) screws below the radio. Also remove (2) screws securing the radio/trim panel assembly. (Figure E)

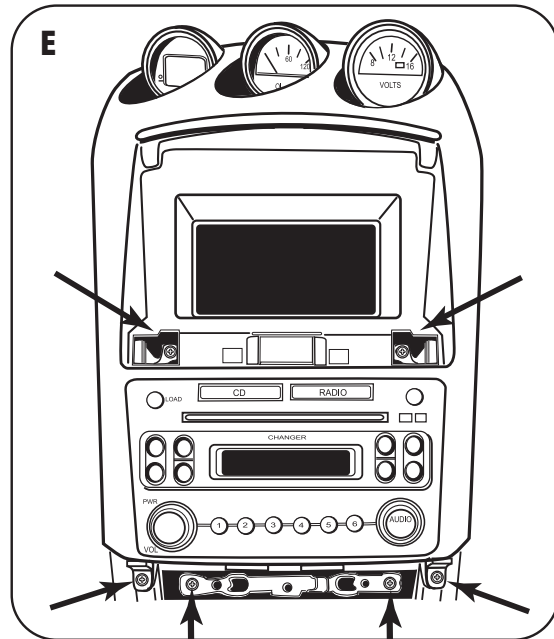

- 7** Unplug and remove the radio / trim panel assembly. (Figure F)

- 8** Remove (4) screws securing the radio to the trim panel and remove the radio.

- 9** Remove (8) screws securing the factory brackets to the radio and remove the brackets from the radio. (These brackets are required for stacked ISO and double DIN installations. You can skip this step for DIN or ISO installations with pocket).

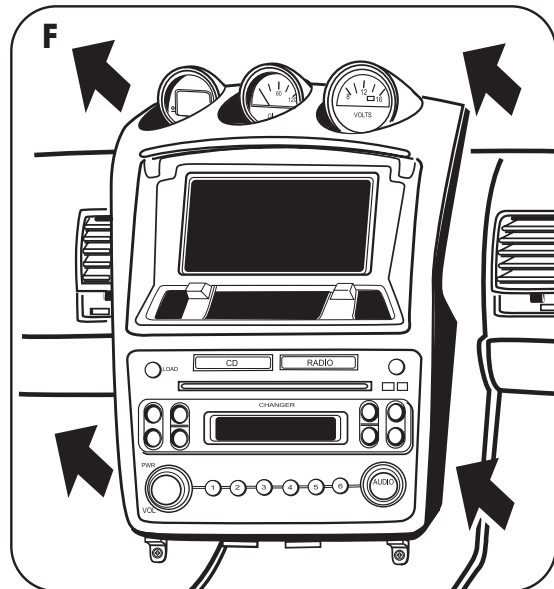

Continue to kit assembly.

DIN MOUNT RADIO PROVISION WITH POCKET

1 Slide DIN cage (supplied with radio) into the radio housing from the front. (Figure A)

2 Secure DIN cage to radio housing by bending the locking tabs outward. (Figure A)

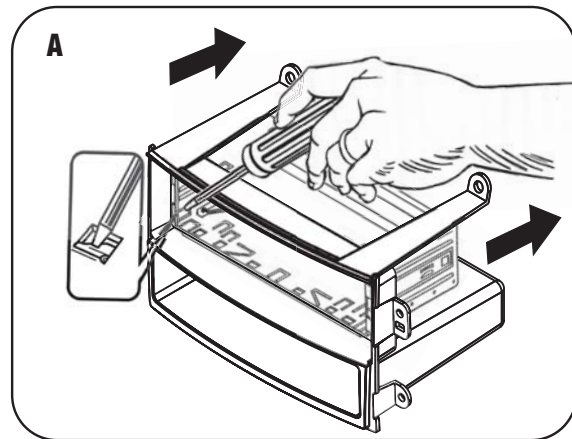

3 Slide the radio into the DIN cage until it snaps into place. (Figure B)

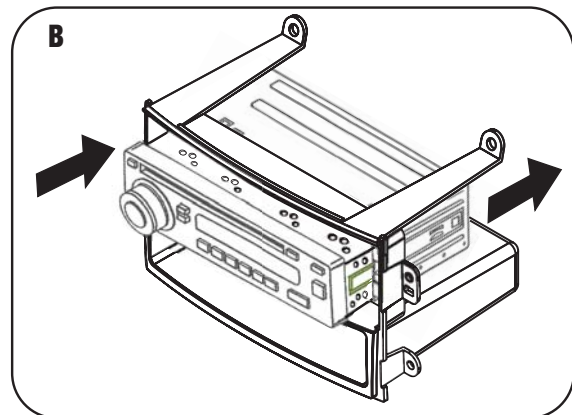

4 Attach the radio / housing assembly to the radio trim panel using the factory screws removed during disassembly. (Figure C)

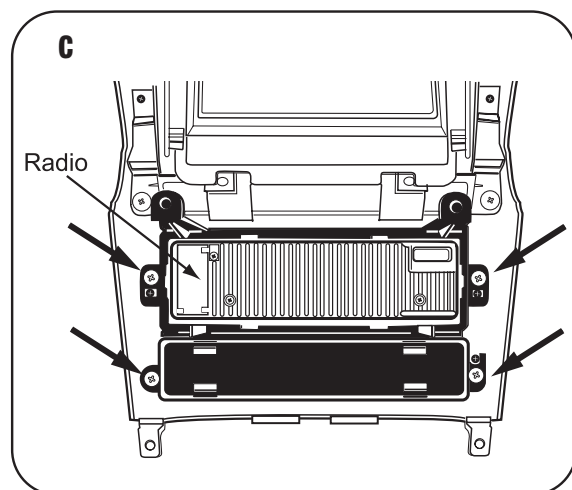

Continue to final assembly.

ISO MOUNT RADIO WITH POCKET

- 1** Align the holes in the ISO brackets with the holes in the radio. Mount the brackets to the radio using screws supplied with the radio. (Figure A)

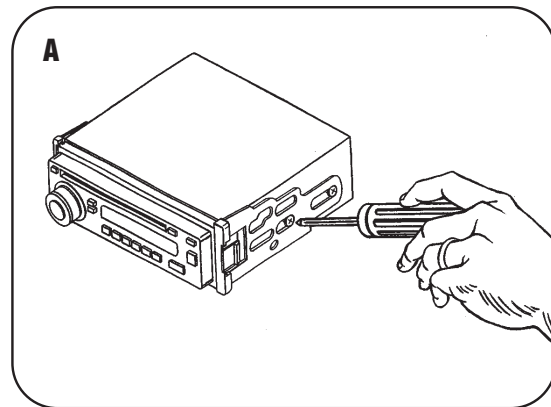

- 2** Slide the radio bracket assembly into the radio housing until it snaps into place. (Figure B)

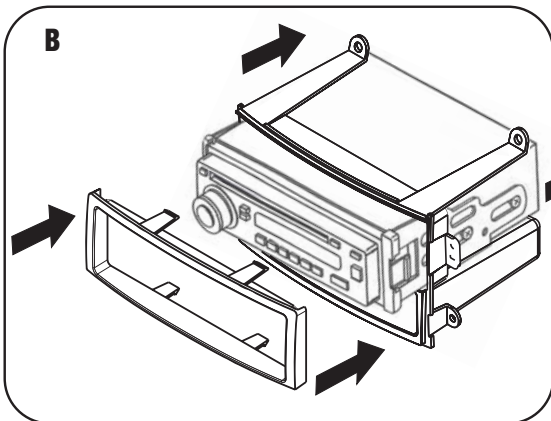

- 3** Snap the ISO trim-plate onto the front of the assembled radio and housing. (Figure B)

- 4** Attach the radio / housing assembly to the radio trim panel using the factory screws removed during disassembly. (Figure C)

Continue to final assembly.

NOTE: To remove the radio unsnap and remove the ISO trim-plate. Using a flat blade screwdriver disengage ISO brackets from the radio housing and slide radio out of radio housing.

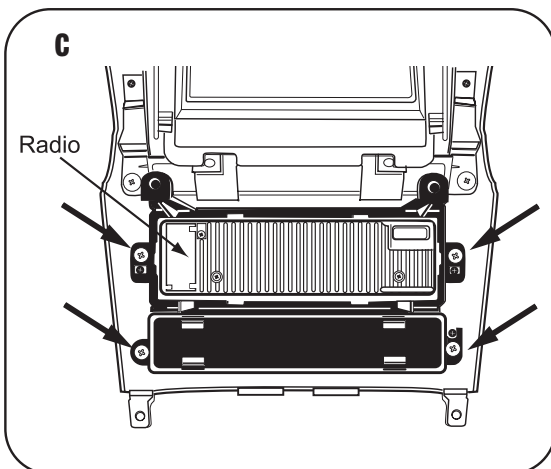

DOUBLE DIN RADIO

- 1** Cut and remove center divider from double DIN trim-plate. (Figure A)
- 2** Place the double DIN trim-plate on the front of the radio. (Figure B)
- 3** Place one of the ISO spacer brackets and the right factory mounting bracket (Removed from radio during disassembly) on the right side of the radio. (The spacer bracket should be between the radio and the factory bracket.) Align the pins on the trim-plate with the holes on the factory bracket and mount the factory bracket to the radio using screws supplied with the radio. (Figure B)
- 4** Place one of the ISO spacer brackets and the left factory mounting bracket (removed from radio during disassembly) on the left side of the radio. The spacer bracket should be between the radio and the factory bracket. Align the pins on the trim-plate with the holes on the factory bracket and mount the factory bracket to the radio using screws supplied with the radio. (Figure B)
- 5** Attach the radio bracket assembly to the radio trim panel using the factory screws removed during disassembly. (Figure C)

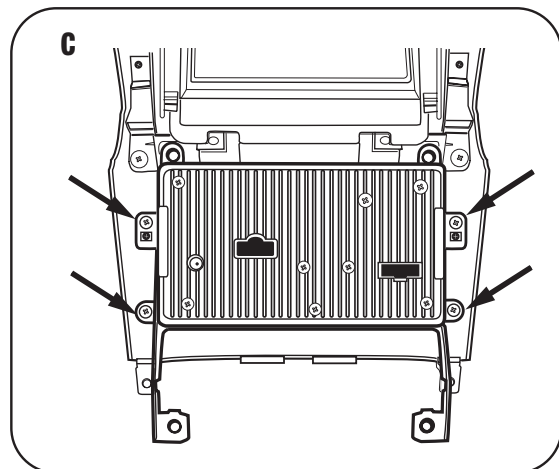
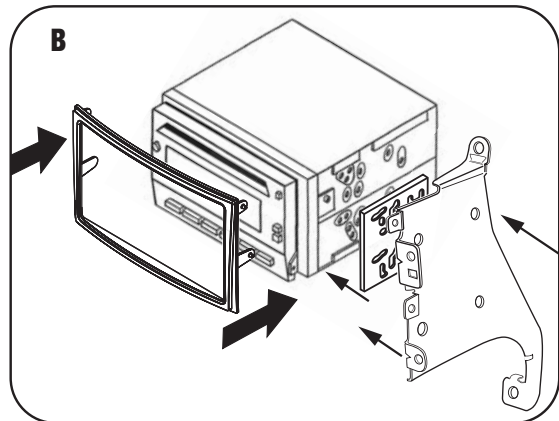
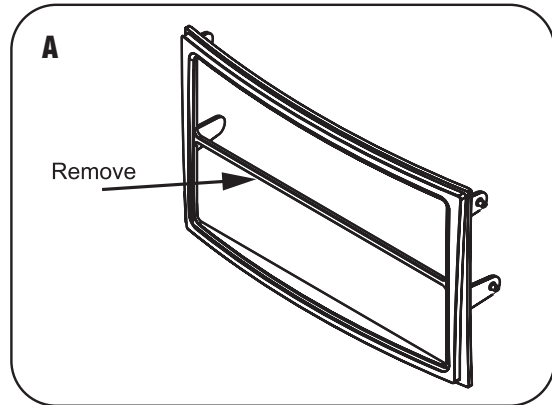

Continue to final assembly.

TWO STACKED ISO MOUNT UNITS

1 Place the double DIN trim-plate on the front of the two ISO units. (Figure A)

2 Place one of the ISO spacer brackets and the right factory mounting bracket (Removed from radio during disassembly) on the right side of the ISO units. (The spacer bracket should be between the ISO units and the factory bracket.) Align the pins on the trim-plate with the holes on the factory bracket and mount the factory bracket to the ISO units using screws supplied with the radio. (Figure A)

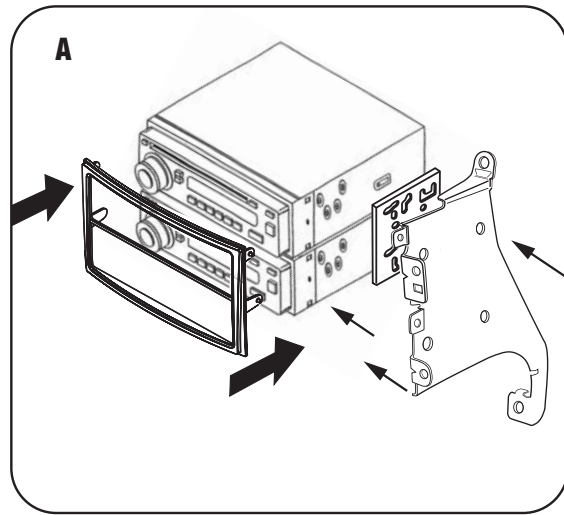

3 Place one of the ISO spacer brackets and the left factory mounting bracket (Removed from radio during disassembly) on the left side of the ISO units. (The spacer bracket should be between the ISO units and the factory bracket.) Align the pins on the trim-plate with the holes on the factory bracket and mount the factory bracket to the ISO units using screws supplied with the radio. (Figure A)

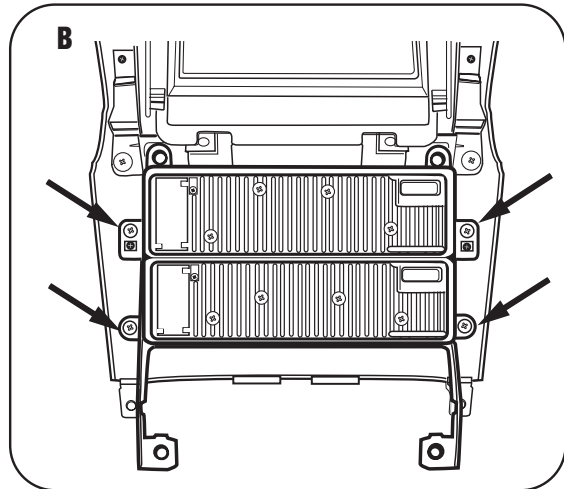

4 Attach the assembled units and brackets to the radio trim panel using the factory screws removed during disassembly. (Figure B)

Continue to final assembly.

FINAL ASSEMBLY

- 1** Locate the factory wiring harness in the dash and make the connection as shown. Metra recommends using the proper mating adapter and making the connections as shown. (Isolate and individually tape off the ends of any unused wires to prevent electrical short circuit.)
- 2** Re-connect the negative battery terminal and test the unit for proper operation.
- 3** Reassemble radio and dash assemblies in reverse order of disassembly.

FINAL WIRING CONNECTIONS

Make wiring connections using the EIA color code chart shown below and the instructions included with the head unit. Metra recommends making connections as shown below; Strip, Splice, Solder, Tape. Isolate and individually tape off ends of any unused wires to prevent electrical short circuit.

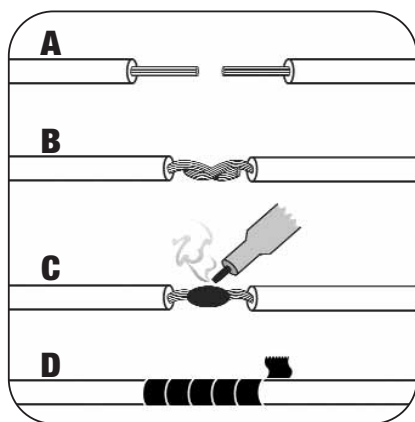

- A) Strip wire ends back 1/2"**
- B) Twist ends together**
- C) Solder**
- D) Tape**

METRA / EIA WIRING CODE

12V Ignition / Acc . . . Red	Right Front (+) Gray
12V Batt / Memory . . Yellow	Right Front (-) Gray / Black
Ground Black*	Left Front (+) White
Power Antenna Blue	Left Front (-) White / Black
Amp Turn-On Blue / White	Right Rear (+) Violet
Amp Ground Black / White	Right Rear (-) Violet / Black
Illumination Orange	Left Rear (+) Green
Dimmer Orange / White	Left Rear (-) Green / Black

***NOTE:** When a Black wire is not present, ground radio to vehicle chassis.
All colors may not be present on all leads due to manufacturer's specifications.

99-7402 INSTRUCTIONS



1-800-221-0932



www.metraonline.com

REV. 05/05/06

© COPYRIGHT 2004 METRA ELECTRONICS CORPORATION

INST99-7402