

## Installation Manual Double DIN Kit



7. Place fascia plate until it snaps in

This kit can be used for cars which were equipped with the following factory radios:

- Chorus Gen.II+
- Concert Gen.II+
- Symphony II
- Symphony II+
- RNS-D
- RNS-E
- RNS-low (BNS 5.0)

*If the car was equipped with a 1 DIN radio like Radio Chorus II, Concert II or Symphony II, you need to change the center console to 2 DIN.  
Your Audi or Seat partner can support you.*

**ALPINE**

## Installation Manual INE-W928R Kit

- Audi A4 (B6/B7)
- Seat Exeo

colour / part-no.:  
black: 381320-84

Compatible with these Alpine navigation devices

### INE-W928R

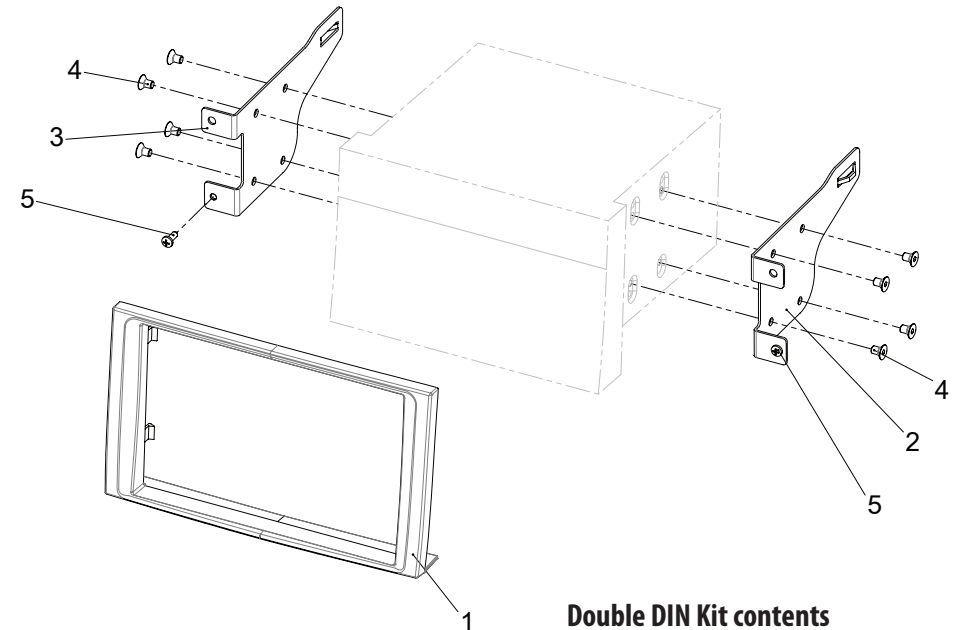

#### Double DIN Kit contents

- (1) Facia Plate
- (2) Mounting Bracket Right
- (3) Mounting Bracket Left
- (4) hexagon socket countersunk flat head screw
- (5) self-tapping convex fillister head screw

# Installation Manual Double DIN Kit



1. Put four radio release keys in the appropriate slots of the OEM radio

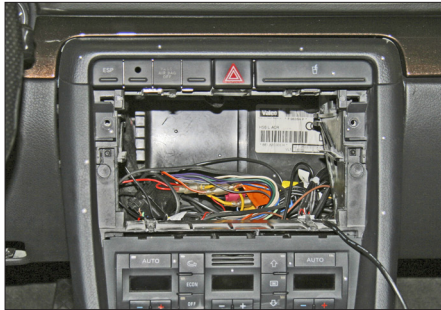
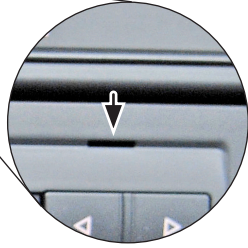

2. Remove the OEM head unit by pulling it towards your direction  
  
(Keep the AUDI OEM screws - they will be needed later)



3. Place mounting frames as positioning help in order to mark the plastic areas that have to be cut away

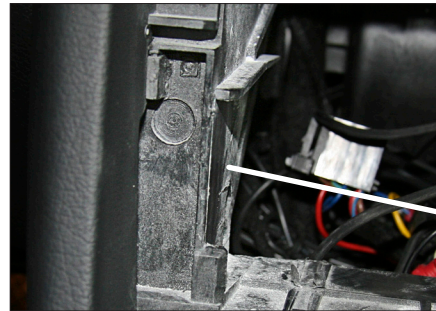
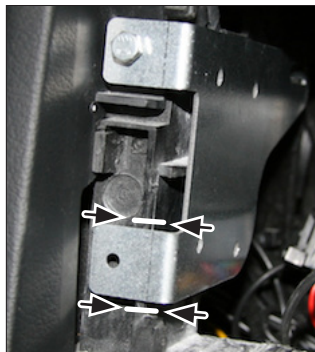

4. Remove mounting frames again and cut away plastic

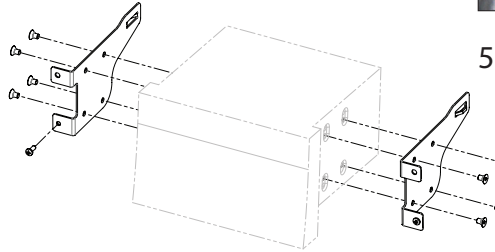
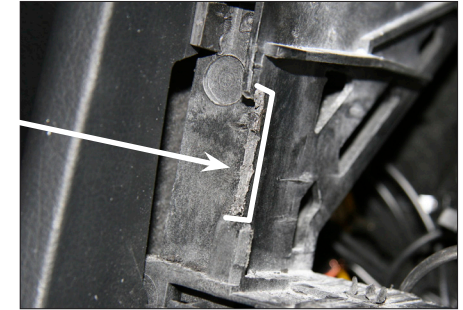

5. Attach metal mounting brackets to Alpine INE-W928R



6. Connect all required circuit points  
Place Alpine INE-W928R and fix it  
  
(OEM screws on top, kit content screws on bottom / see arrows)

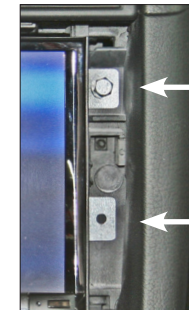

OEM screw

kit content screw